

# EFFECT OF OPERATION CAPACITY BUILDING ON EMPLOYEE PRODUCTIVITY IN NON GOVERNMENTAL ORGANISATIONS IN RWANDA: A CASE OF OXFAM RWANDA

<sup>1</sup>ANNICK BURABYO, <sup>2</sup>Dr. PATRICK MULYUNGI

<sup>1,2</sup>Jomo Kenyatta University of Agriculture and Technology

---

**Abstract:** In Rwanda, capacity building means different things to some of different organizations, driven by their strategic needs and deficiencies and, essentially, regardless of their status and future goals. A general objective of this study is to examine the effect of operation capacity building on employee productivity in non-governmental organisations in Rwanda. On this research, Researcher used descriptive research design. The study population was comprised 34 staff of Oxfam Rwanda main branch. Researcher used Primary data and the results of the study were analyzed by using qualitative and quantitative data analysis, percentages and frequencies for comparison of opinions was generated. The coefficients of model fitness on how operation capacity building explains employee productivity in non -governmental organisations in Rwanda, especial in OXFAM Rwanda. Employee's productivity has an overall correlation with operation of capacity building of 0.733 which is strong and positive. This means that approximately 73.3% variations of employee's productivity are explained by the capacity building at 5% level of significance. These indicate good fit of the regression equation used. The overall significance of the regression estimation model. It indicates that the model is significant in explaining the relationship between operation capacity building and employee productivity at 5% level of significance. Analysis of Variance shows that f-calculated is greater than f – critical that is  $6.321 > 0.00$ . More so training is considered as of great important to all the levels as it improves job commitment encourages specialization of employees. Human Resource Development practitioners should consider desired work-related attitudes such as organizational motivation, employee turnover, employee productivity, punctuality, organizational performance, job satisfaction and motivation to be an additional outcome of employee productivity.

**Keywords:** operation capacity building, employee productivity, employee turnover, job satisfaction.

---

## 1. BACKGROUND OF THE STUDY

In most organizations whether large or small, there are three basic elements to look out for. The first is the human element which comprises of employee working in the organization, second is the method of operation needed to enable the organization function effectively both internally and externally, while the third element is how to enhance productivity and the efficiency of employees. This is where capacity building and manpower development come into play. Capacity building, training and manpower development have over the years risen to a new found importance, so much so that numerous literatures abound on the topic both within the academic and non-academic circles. It is much more than training and includes; human resources development, which involves the process of equipping individuals with skills, understanding, access to information, knowledge, and training which enables them to perform effectively (Bambrough, 2001).

Capacity building has its origin in the United Nations and its quest to develop people and entities. The lead with the UN system for action and thinking in this area was given to United Nations Development Programme (UNDP) and has offered guidance to its staff and governments on what was then called institution building. This involves building up abilities of basic national organizations, in areas such as Civil Aviation, Meteorology, Health, Education, Nutrition etc, to do their task well (Jonathan, 2012). UNDP recognizes that the capacity building is a long-term process in which all stakeholders participate (Ministries, Local authorities, Non-governmental organizations, Professional Associations etc.). This creates enabling environment with appropriate policy and legal frameworks, institutional development including community participation (of women in particular), human resources development, and strengthening of managerial systems.

According to (United Nations Committee of Experts on Public Administration, 2006), capacity building takes place at three levels, that is, at the individual level, an institutional level and the societal level. Capacity building on an individual level means the development of conditions that enable individuals to build and enhance existing knowledge and skills. Additionally, it requires the conditions that will allow individuals to engage in the process of learning and adapting to change (UNCEPA, 2006).

Institutional level capacity building should involve modernizing existing institutions and supporting them in forming sound policies, organizational structures, and effective methods of management and revenue control. The establishment of strong interactive public administration system that receives feedback from the population and makes public administrators more accountable and responsive is the goal of societal level capacity building (UNCEPA, 2006). The vision of the organization is "A world free from all forms of exploitation and discrimination where everyone has the opportunity to realize their potential". The mission is "To empower people and communities in situations of poverty, illiteracy, disease and social injustice". Values are Integrity, Innovation, Inclusiveness and Effectiveness. The objectives of the organization are Poverty alleviation and empowerment of the poor especially women and children.

One of the challenging tasks of any organization can be making employees to multitask highly in different roles with one shared vision, mission, values and objectives. This leads to employees having a positive attitude towards capacity building those results into job satisfaction (Herbison, 2009). On this note, there are quite a good number of development organizations operating in African countries like Rwanda, they include the world vision, save the children, acclaim Africa, feed the children and OXFAM. The researcher found it viable to conduct a research about capacity building and employee productivity in OXFAM.

This study will focus at OXFAM, an international confederation of 17 affiliates which works in over 90 countries to find lasting solutions to poverty, inequality and injustice. Oxfam has been working in Rwanda since the 1970's, acting as a catalyst as well as a facilitator, bringing different actors together while influencing how sustainable change happens. Oxfam work to ensure that poor people improve their lives and have a say in decisions that affect them. In a world rich in resources, Oxfam believes that poverty is not a fact of life but an injustice to be overcome. Oxfam strives to ensure everyone can be secure, healthy, skilled sage, heard and equal (Oxfam, 2014).

The department of human resource at Oxfam (Oxfam, 2010) takes capacity building as enhancing the abilities of individuals, organizations and systems to undertake and disseminate high quality research efficiently and effectively. Capacity building efforts can be designed to serve individuals, organizations, geographical or interest communities, or the nonprofit sector as a whole. Furthermore, the intensity and duration of the effort can distinguish a capacity building engagement as either aimed at implementing new systems (short term) or achieving wider organizational change (long-term). These efforts can further be usefully classified based on the areas of organizational life they seek to affect: external relationships, internal structure, leadership, and/or internal management systems.

The goal of capacity building, according to (OXFAM, 2010), is to facilitate individual and organizational learning which builds social capital and trust, develops knowledge, skills and attitudes and when successful, creates an organizational culture and a set of capabilities which enables organizations to set objectives, achieve results, solve problems, and create adaptive procedures which enable them to survive in the long run. Staff capacity building has been identified as part of an organizational strategy to improve overall productivity, motivate staff to deliver high quality services and create an ongoing commitment to innovation and system improvement (Philips, 2011). Viewed from this perspective; staff training is an integral part of a larger human resources investment strategy designed to transform workforce service delivery system into "high performance" organizations that strive continuously to improve service quality and customer satisfaction.

Other forms of capacity building that are being implemented at OXFAM include mentoring, delegation, workshops and seminars and induction. In addition to contributing to the development of technical outputs, human capacity building can directly benefit both the newly trained, mentored and inducted individuals and the organization that they work for. The benefits to trainees are the most direct link between capacity building and impact. The main benefits to trainees include improvements in confidence, competence, promotion and higher income Grip AD, (Saverman, 2010). Also, the benefits of capacity building can flow to the trained individual, other workers in the organization, the organization as a whole and communities.

## 2. STATEMENT OF THE PROBLEM

The Oxfam Strategic Plan (2010 - 2014), capacity building is a major strategy to the efficient sustainability of the organization as a whole. It is likely to orient at least 75% of employed workforce both internally and externally. If carried out systematically well year after year, it will accounts for 85% of the expected output of the employees. These nongovernmental organizations are a source of employment for most people in Rwanda. This picture however is bound to worsen given the challenges capacity building is facing. Capacity building is designed and implemented in different ways and practices in a different ways as per the different organizations in Rwanda (Karenzi, 2014).

Karenzi (2014) reveals that in Rwanda, capacity building means different things to different organizations, driven by their strategic needs and deficiencies and, essentially, regardless of their status and future goals. Consequently, most NGO's have misinterpreted capacity building variables. The evaluation of Oxfam strategic plan (2010-2014) reveals that employee's productivity declined by 10% from 75% to 65% for that period and this has been supported by Karenzi report which stated that the level of employee performance among NGO's in Rwanda is in chaos (Karenzi, 2014). The current state of the NGO's where capacity building is being enhanced is below the international standards (DFID, 2014).

None government organization have invested much effort including funds and time in capacity development of their employees with the expectation of increasing the productivity and using it as employee retention incentive, however, performance and productivity are still challenges for most of the institutions. Different organizations introduced learning systems for its employees including peer to peer learning and online learning system. Despite the widespread effort invested by the organization, they are still struggling to enjoy the employee productivity for better the outputs delivery.

This study therefore seeks to establish the effect of capacity building on Employee Productivity in NGO's taking Oxfam Rwanda as a case study. The researcher would like to find out if there is relationship between the capacity building and employee productivity in none government organization.

### Specific Objective:

To analyzing the effect of training on employee performance in Oxfam Rwanda

## 3. CONCEPTUAL FRAMEWORK

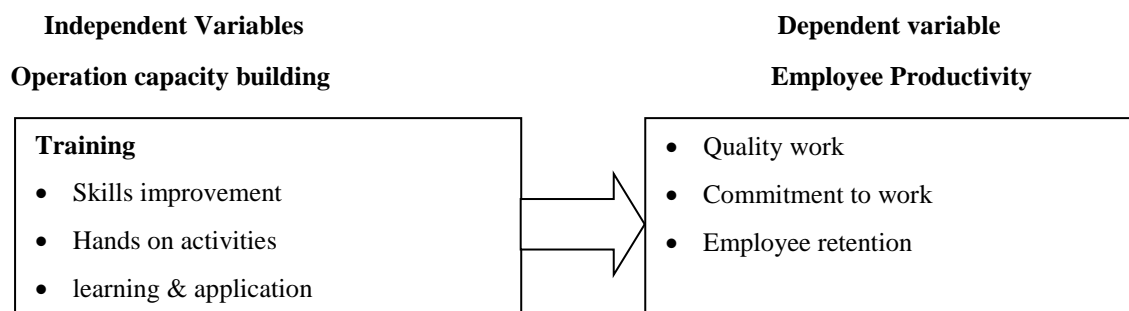

## 4. RESEARCH DESIGN

This study used descriptive research design. (Frank & Nachimias, 2006), defined research design as arrangement of conditions for data collection and data analysis in a manner that aim to combine relevance to the research purpose as well with economy in procedure. Descriptive research design was used qualitative approach in order to describe the effect of capacity building on employee productivity in non government organizations in Rwanda. The qualitative approach was used because the study was focused on the views of the employees.

## 5. STUDY POPULATION AND SAMPLING TECHNIQUE

The target population contains members of a group that a researcher is interested in studying. The results of the study generalized to this population, because they all have significant traits in common (Nachimas, 2008). The study population was the staff of Oxfam-Rwanda at Kigali Headquarters. The total population is 34 employees of Oxfam Rwanda.

For the purpose of this study, in this study researcher was used census technique, is where researcher was taken all staff of OXFAM-Rwanda. There is no need for sampling technique since the entire population was participated in the study.

## 6. RESULTS AND DISCUSSION

**Table 1: The influence of training on the employee productivity**

Statements	SA	A	UN	D	SD
1. Employees are sponsored for the training programs.	32 (94.1%)	2(5.9%)	-	-	-
2. Different Training methods are carefully selected and used	34(100%)	-	-	-	-
3. Training needs of my department are properly assessed	20(58.8%)	14(41.2%)	-	-	-
4. Training for new staff is given adequate importance	34 (100%)	-	-	-	-
5. Most of the employees consider training is vital for job productivity.	34 (100%)	-	-	-	-
6. Competency level of employees increases due to trainings.	26(76.5%)	7(20.65)	-	1(2.6%)	-

Source: Primary data, 2018

All the above statements are regarding on how training influenced the employee productivity in OXFAM-Rwanda. The perceptions of the respondent's shows that 94.1% and 5.9% are strongly appreciated the training programs and how those training have been influenced the employee's productivity are. 100% of the respondents appreciated the different training offer by OXFAM-Rwanda. Training needs of different department in OXFAM-Rwanda are properly assessed as appreciated by 58.8% and 14.2%.

100% of the respondents show that the most of the employees consider training is vital for job productivity.

Capacity building in nongovernmental organisations, managers must continue to develop superior knowledge, skills and experience within their workforce, staffing programmes focus on identifying, recruiting and hiring the best and the brightest talent available. Training programmes complement these staffing practices to provide skills enhancement, particularly in areas that cannot be transferred to another company if an employee should leave in addition, employees need opportunities for development on the job. There is some evidence to suggest that successful employee productivity of capacity building is contingent upon where the activities are directed. Generally, capacity building efforts have tended to focus on technical training, such as strategic planning and financial management, under the assumption that this will improve organizational effectiveness (Ebrahim, 2014).

**Table 2: ANOVA<sup>b</sup>**

Model		Sum of Squares	Df	Mean Square	F	Sig.
1	Regression	24.612	3	6.401	6.321	.000 <sup>a</sup>
	Residual	.742	31	.010		
	Total	32.355	34			
a. Predictors: (Constant), Training						
a. Dependent Variable: Employee productivity.						

Anova Table shows the overall significance of the regression estimation model. It indicates that the model is significant in explaining the relationship between operation capacity building and employee productivity at 5% level of significance. Analysis of Variance shows that f-calculated is greater than f-critical that is  $6.321 > 0.00$ . This implies that the regression equation was well specified and therefore the co-efficient of the regression shows that there is a strong relationship between operation capacity building and employee productivity. The analysis of variance of the predictors of the model has a significance of 0.000.

## 7. CONCLUSION

The study was about capacity building and employee productivity. It is widely assumed that training contributed to the productivity of OXFAM employees. Using the ANOVA test it was discovered that training has more significant effect on employee productivity at the 5% level.

More so training is considered as of great important to all the levels as it improves job commitment, encourages specialization of employees, address poor attitude to work and promotes positive and significant performance with multiplier effect increases competition and employee productivity. Training has contributed immensely to employee's boldness and confidence.

## 8. RECOMMENDATIONS

From the findings and conclusions above, it can be recommended that, capacity building is positively correlated to employee productivity. Therefore, the OXFAM through the Human Resource Departments should continue to plan and execute training programmes that are in line with objectives of the firm and those that match employees' abilities and skills to enhance effective employee productivity. Human Resource Development practitioners should consider desired work-related attitudes such as organizational motivation, employee turnover, employee productivity, punctuality, organizational performance, job satisfaction and motivation to be an additional outcome of employee productivity. Since employee productivity depends on the amount of time an individual is physically present at a job and also the degree to which he or she is "mentally present" or efficiently functioning while present at a job. OXFAM-Rwanda must address employees' satisfaction, health, and morale in order to maintain high worker productivity.

## REFERENCES

- [1] Bambrough, (2001). *Human Resource Management: A contemporary perspective*, pitman
- [2] DFID, (2014), Relationship between on the Job Training and Employee's Performance in Courier Companies in Dar es Salaam, Tanzania" *International Journal of Humanities & Social Science*, Nov.
- [3] Frank and Nachimias, (2006), Examining the Relationship between Training, Motivation and Employees Job Performance – The Moderating Role of Person Job Fit, *Journal of Basic and Applied Scientific Research*,
- [4] Herbison, (2009), *Research methods Qualitative and Quantitative* Newyork: Palgrave Macmillan
- [5] Herbison, (2009), *Personnel Management*, a new approach, prentice Hall, London
- [6] Jonathan, (2012). Training, Wage Growth, and Job Performance: Evidence from a company database. *Journal of Labour Economics* 13, 401-425.
- [7] Karenzi, A,M (2014), *Human Resource Management and Development*, Current issues and Theme,
- [8] Oxfam, (2014). Examining the Relationship between Training, Motivation and Employees Job Performance – The Moderating Role of Person Job Fit, *Journal of Basic and Applied Scientific Research*,
- [9] Philips, (2011), *Human Resource Management – An experiential approach*. New Delhi. India: Tata McGraw Hill Publishing Company Limited.
- [10] Saverman, (2010), Effects of Training Framing, General Self-efficacy and Training Motivation
- [11] UNCEPA, (2006), "Partnerships between local governments and community-based organisations: exploring the scope for synergy". In: *Public Administration and Development*, 23, 361-371.
- [12] United Nations Committee of Experts on Public Administration, (2006), *First, break all the rules: What the world's greatest managers do differently*. New York, NY: Simon & Shuster.